



# Low-Power, Rail-to-Rail Output, 16-Bit Serial Input DIGITAL-TO-ANALOG CONVERTER

## FEATURES

- **microPOWER OPERATION:** 250 $\mu$ A at 5V
- **POWER-ON RESET TO ZERO**
- **POWER SUPPLY:** +2.7V to +5.5V
- **GUARANTEED MONOTONIC BY DESIGN**
- **SETTLING TIME:** 10 $\mu$ s to  $\pm$ 0.003 FSR
- **LOW-POWER SERIAL INTERFACE WITH SCHMITT-TRIGGERED INPUTS**
- **ON-CHIP OUTPUT BUFFER AMPLIFIER, RAIL-TO-RAIL OPERATION**
- **SYNC INTERRUPT FACILITY**
- **MSOP-8 PACKAGE**

## APPLICATIONS

- **PROCESS CONTROL**
- **DATA ACQUISITION SYSTEMS**
- **CLOSED-LOOP SERVO-CONTROL**
- **PC PERIPHERALS**
- **PORTABLE INSTRUMENTATION**
- **PROGRAMMABLE ATTENUATION**

## DESCRIPTION

The DAC8531 is a low-power, single, 16-bit buffered voltage output Digital-to-Analog Converter (DAC). Its on-chip precision output amplifier allows rail-to-rail output swing to be achieved. The DAC8531 uses a versatile three-wire serial interface that operates at clock rates up to 30MHz and is compatible with standard SPI™, QSPI™, Microwire™ and DSP interfaces.

The DAC8531 requires an external reference voltage to set the output range of the DAC. The DAC8531 incorporates a power-on-reset circuit that ensures that the DAC output powers up at zero volts and remains there until a valid write takes place to the device. The DAC8531 contains a power-down feature, accessed over the serial interface, that reduces the current consumption of the device to 200nA at 5V.

The low power consumption of this part in normal operation makes it ideally suited to portable battery-operated equipment. The power consumption is 0.5mW at 5V reducing to 1 $\mu$ W in power-down mode.

The DAC8531 is available in an MSOP-8 package.

SPI and QSPI are registered trademarks of Motorola.  
Microwire is a registered trademark of National Semiconductor.

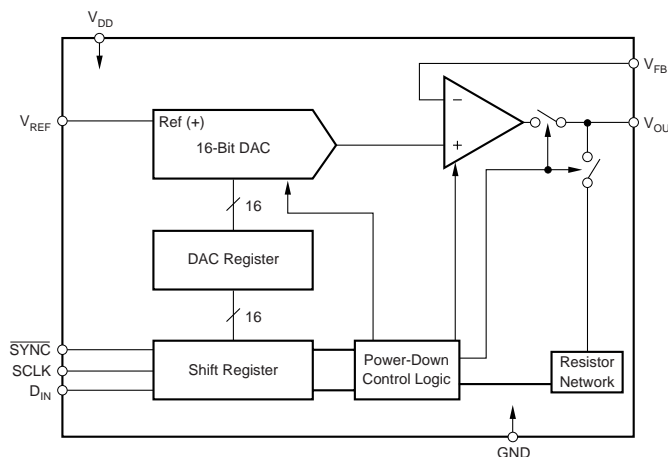

Please be aware that an important notice concerning availability, standard warranty, and use in critical applications of Texas Instruments semiconductor products and disclaimers thereto appears at the end of this data sheet.

## ABSOLUTE MAXIMUM RATINGS<sup>(1)</sup>

V <sub>DD</sub> to GND .....	-0.3V to +6V
Digital Input Voltage to GND .....	-0.3V to +V <sub>DD</sub> + 0.3V
V <sub>OUT</sub> to GND .....	-0.3V to +V <sub>DD</sub> + 0.3V
Operating Temperature Range .....	-40°C to +105°C
Storage Temperature Range .....	-65°C to +150°C
Junction Temperature Range (T <sub>J</sub> max) .....	+150°C
Power Dissipation .....	(T <sub>J</sub> max - T <sub>A</sub> )/θ <sub>JA</sub>
θ <sub>JA</sub> Thermal Impedance .....	206°C/W
θ <sub>JC</sub> Thermal Impedance .....	44°C/W
Lead Temperature, Soldering:	
Vapor Phase (60s) .....	+215°C
Infrared (15s) .....	+220°C

NOTE: (1) Stresses above those listed under "Absolute Maximum Ratings" may cause permanent damage to the device. Exposure to absolute maximum conditions for extended periods may affect device reliability.



## ELECTROSTATIC DISCHARGE SENSITIVITY

This integrated circuit can be damaged by ESD. Texas Instruments recommends that all integrated circuits be handled with appropriate precautions. Failure to observe proper handling and installation procedures can cause damage.

ESD damage can range from subtle performance degradation to complete device failure. Precision integrated circuits may be more susceptible to damage because very small parametric changes could cause the device not to meet its published specifications.

## PACKAGE/ORDERING INFORMATION

PRODUCT	MINIMUM RELATIVE ACCURACY (LSB)	DIFFERENTIAL NONLINEARITY (LSB)	PACKAGE	PACKAGE DRAWING NUMBER	SPECIFICATION TEMPERATURE RANGE	PACKAGE MARKING	ORDERING NUMBER <sup>(1)</sup>	TRANSPORT MEDIA
DAC8531E "	±64 "	±1 "	MSOP-8 "	337 "	-40°C to +105°C "	D31E "	DAC8531E/250 DAC8531E/2K5	Tape and Reel Tape and Reel

NOTE: (1) Models with a slash (/) are available only in Tape and Reel in the quantities indicated (e.g., /2K5 indicates 2500 devices per reel). Ordering 2500 pieces of "DAC8531E/2K5" will get a single 2500-piece Tape and Reel.

## ELECTRICAL CHARACTERISTICS

V<sub>DD</sub> = +2.7V to +5.5V. -40°C to +105°C, unless otherwise specified.

PARAMETER	CONDITIONS	DAC8531E			UNITS
		MIN	TYP	MAX	
<b>STATIC PERFORMANCE<sup>(1)</sup></b>					
Resolution		16			Bits
Relative Accuracy				±64	LSB
Differential Nonlinearity	Guaranteed Monotonic by Design			±1	LSB
Zero Code Error	All Zeroes Loaded to DAC Register		+5	+20	mV
Full-Scale Error	All Ones Loaded to DAC Register		-0.15	-1.25	% of FSR
Gain Error				±1.25	% of FSR
Zero Code Error Drift			±20		μV/°C
Gain Temperature Coefficient			±5		ppm of FSR/°C
<b>OUTPUT CHARACTERISTICS<sup>(2)</sup></b>					
Output Voltage Range	To ±0.003% FSR	0		V <sub>REF</sub>	V
Output Voltage Settling Time	0200 <sub>H</sub> to FD00 <sub>H</sub>		8	10	μs
	R <sub>L</sub> = 2kΩ; 0pF < C <sub>L</sub> < 200pF		12		μs
	R <sub>L</sub> = 2kΩ; C <sub>L</sub> = 500pF		1		V/μs
Slew Rate			1		V/μs
Capacitive Load Stability	R <sub>L</sub> = ∞		470		pF
	R <sub>L</sub> = 2kΩ		1000		pF
Code Change Glitch Impulse	1LSB Change Around Major Carry		20		nV-s
Digital Feedthrough			0.5		nV-s
DC Output Impedance			1		Ω
Short-Circuit Current	V <sub>DD</sub> = +5V		50		mA
	V <sub>DD</sub> = +3V		20		mA
Power-Up Time	Coming Out of Power-Down Mode				
	V <sub>DD</sub> = +5V		2.5		μs
	Coming Out of Power-Down Mode				
	V <sub>DD</sub> = +3V		5		μs
<b>REFERENCE INPUT</b>					
Reference Current	V <sub>REF</sub> = V <sub>DD</sub> = +5V		35	45	μA
	V <sub>REF</sub> = V <sub>DD</sub> = +3.6V		20	30	μA
Reference Input Range		0		V <sub>DD</sub>	V
Reference Input Impedance			150		kΩ

NOTES: (1) Linearity calculated using a reduced code range of 485 to 64714; output unloaded. (2) Guaranteed by design and characterization, not production tested.

# ELECTRICAL CHARACTERISTICS (Cont.)

$V_{DD} = +2.7V$  to  $+5.5V$ .  $-40^{\circ}C$  to  $+105^{\circ}C$ , unless otherwise specified.

PARAMETER	CONDITIONS	DAC8531E			UNITS
		MIN	TYP	MAX	
<b>LOGIC INPUTS</b> <sup>(2)</sup>					
Input Current				$\pm 1$	$\mu A$
$V_{INL}$ , Input Low Voltage	$V_{DD} = +5V$			0.8	V
$V_{INL}$ , Input Low Voltage	$V_{DD} = +3V$			0.6	V
$V_{INH}$ , Input High Voltage	$V_{DD} = +5V$	2.4			V
$V_{INH}$ , Input High Voltage	$V_{DD} = +3V$	2.1			V
Pin Capacitance				3	pF
<b>POWER REQUIREMENTS</b>					
$V_{DD}$		2.7		5.5	V
$I_{DD}$ (normal mode)	DAC Active and Excluding Load Current				
$V_{DD} = +3.6V$ to $+5.5V$	$V_{IH} = V_{DD}$ and $V_{IL} = GND$		250	400	$\mu A$
$V_{DD} = +2.7V$ to $+3.6V$	$V_{IH} = V_{DD}$ and $V_{IL} = GND$		240	390	$\mu A$
$I_{DD}$ (all power-down modes)					
$V_{DD} = +3.6V$ to $+5.5V$	$V_{IH} = V_{DD}$ and $V_{IL} = GND$		0.2	1	$\mu A$
$V_{DD} = +2.7V$ to $+3.6V$	$V_{IH} = V_{DD}$ and $V_{IL} = GND$		0.05	1	$\mu A$
<b>POWER EFFICIENCY</b>					
$I_{OUT}/I_{DD}$	$I_{LOAD} = 2mA$ , $V_{DD} = +5V$		89		%
<b>TEMPERATURE RANGE</b>					
Specified Performance		-40		+105	$^{\circ}C$

## PIN CONFIGURATIONS

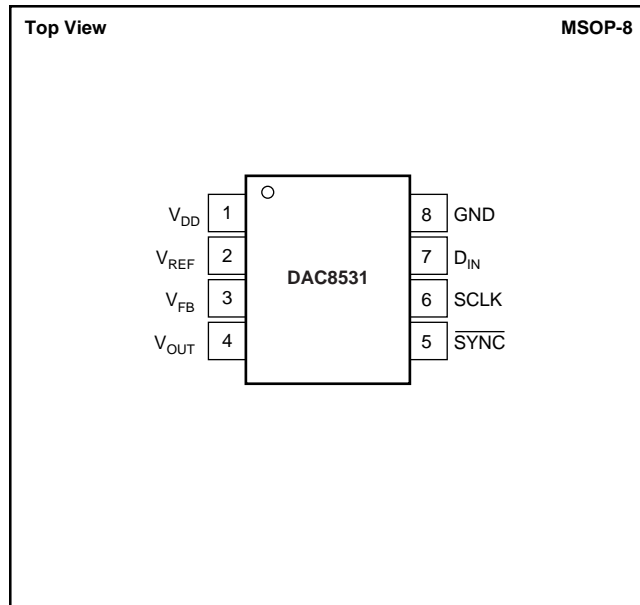

## PIN DESCRIPTION

PIN	NAME	DESCRIPTION
1	$V_{DD}$	Power-Supply Input, $+2.7V$ to $+5.5V$ .
2	$V_{REF}$	Reference Voltage Input
3	$V_{FB}$	Feedback connection for the output amplifier.
4	$V_{OUT}$	Analog output voltage from DAC. The output amplifier has rail-to-rail operation.
5	$\overline{SYNC}$	Level-triggered control input (active LOW). This is the frame synchronization signal for the input data. When $\overline{SYNC}$ goes LOW, it enables the input shift register and data is transferred in on the falling edges of the following clocks. The DAC is updated following the 24th clock cycle unless $\overline{SYNC}$ is taken HIGH before this edge, in which case the rising edge of $\overline{SYNC}$ acts as an interrupt and the write sequence is ignored by the DAC8531.
6	SCLK	Serial Clock Input. Data can be transferred at rates up to 30MHz.
7	$D_{IN}$	Serial Data Input. Data is clocked into the 16-bit input shift register on the falling edge of the serial clock input.
8	GND	Ground reference point for all circuitry on the part.

# TIMING CHARACTERISTICS(1, 2)

$V_{DD} = +2.7V$  to  $+5.5V$ ; all specifications  $-40^{\circ}C$  to  $+105^{\circ}C$  unless otherwise noted.

PARAMETER	DESCRIPTION	CONDITIONS	DAC8531E			UNITS
			MIN	TYP	MAX	
$t_1^{(3)}$	SCLK Cycle Time	$V_{DD} = 2.7V$ to $3.6V$ $V_{DD} = 3.6V$ to $5.5V$	50 33			ns ns
$t_2$	SCLK HIGH Time	$V_{DD} = 2.7V$ to $3.6V$ $V_{DD} = 3.6V$ to $5.5V$	13 13			ns ns
$t_3$	SCLK LOW Time	$V_{DD} = 2.7V$ to $3.6V$ $V_{DD} = 3.6V$ to $5.5V$	22.5 13			ns ns
$t_4$	$\overline{SYNC}$ to SCLK Rising Edge Setup Time	$V_{DD} = 2.7V$ to $3.6V$ $V_{DD} = 3.6V$ to $5.5V$	0 0			ns ns
$t_5$	Data Setup Time	$V_{DD} = 2.7V$ to $3.6V$ $V_{DD} = 3.6V$ to $5.5V$	5 5			ns ns
$t_6$	Data Hold Time	$V_{DD} = 2.7V$ to $3.6V$ $V_{DD} = 3.6V$ to $5.5V$	4.5 4.5			ns ns
$t_7$	SCLK Falling Edge to $\overline{SYNC}$ Rising Edge	$V_{DD} = 2.7V$ to $3.6V$ $V_{DD} = 3.6V$ to $5.5V$	0 0			ns ns
$t_8$	Minimum $\overline{SYNC}$ HIGH Time	$V_{DD} = 2.7V$ to $3.6V$ $V_{DD} = 3.6V$ to $5.5V$	50 33			ns ns

NOTES: (1) All input signals are specified with  $t_R = t_F = 5ns$  (10% to 90% of  $V_{DD}$ ) and timed from a voltage level of  $(V_{IL} + V_{IH})/2$ . (2) See Serial Write Operation timing diagram, below. (3) Maximum SCLK frequency is 30MHz at  $V_{DD} = +3.6V$  to  $+5.5V$  and 20MHz at  $V_{DD} = +2.7V$  to  $+3.6V$ .

## SERIAL WRITE OPERATION

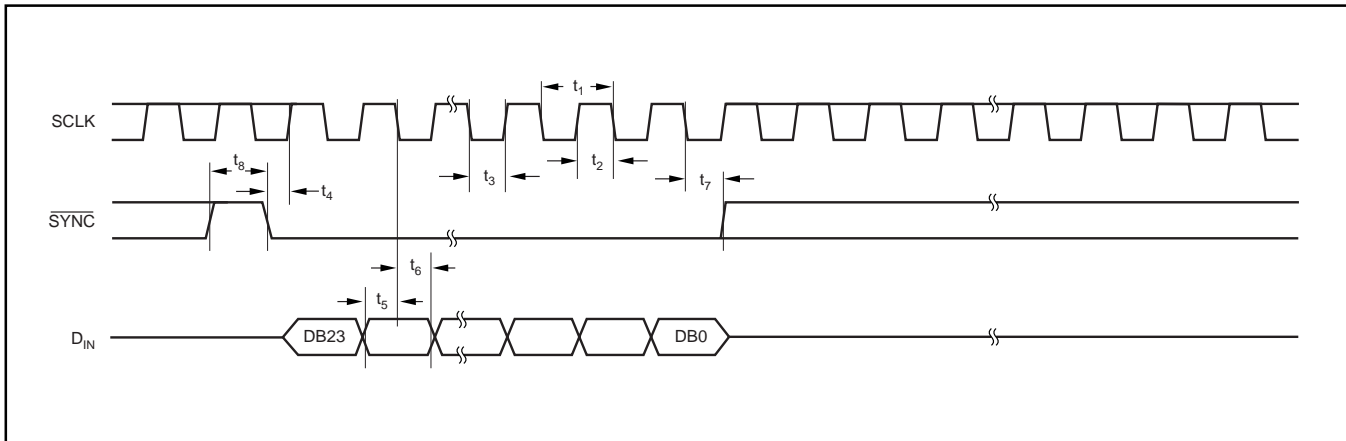

# TYPICAL CHARACTERISTICS: $V_{DD} = +5V$

At  $T_A = +25^\circ\text{C}$ ,  $+V_{DD} = +5V$ , unless otherwise noted.

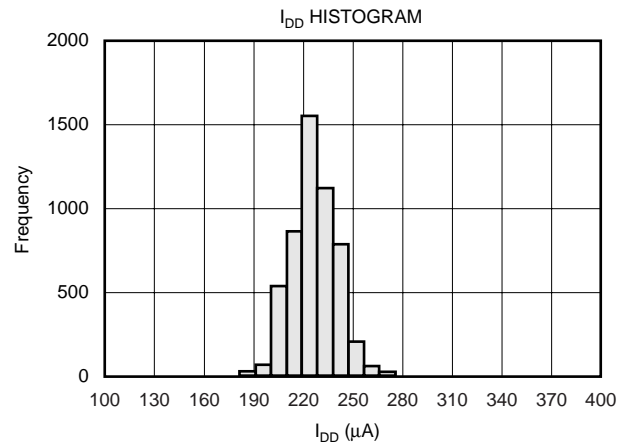
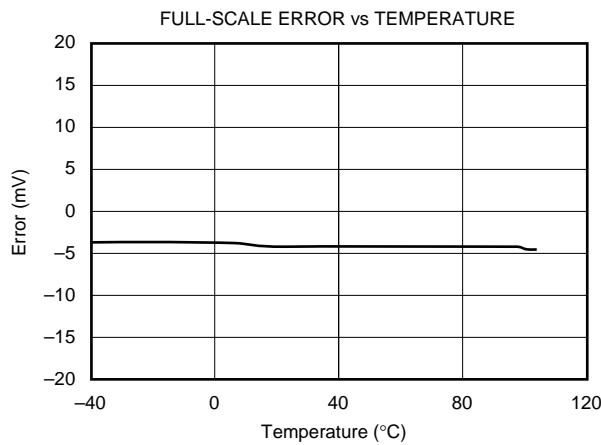
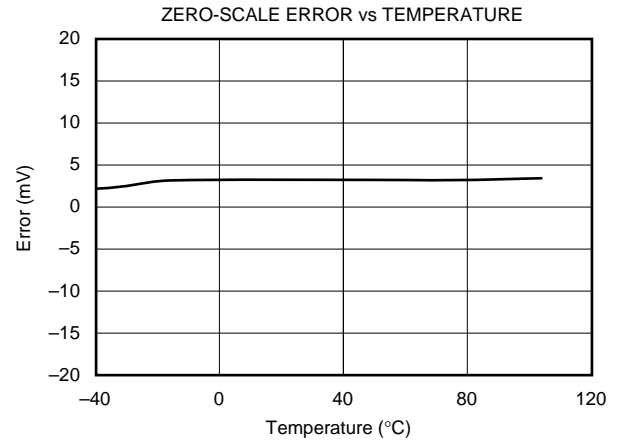
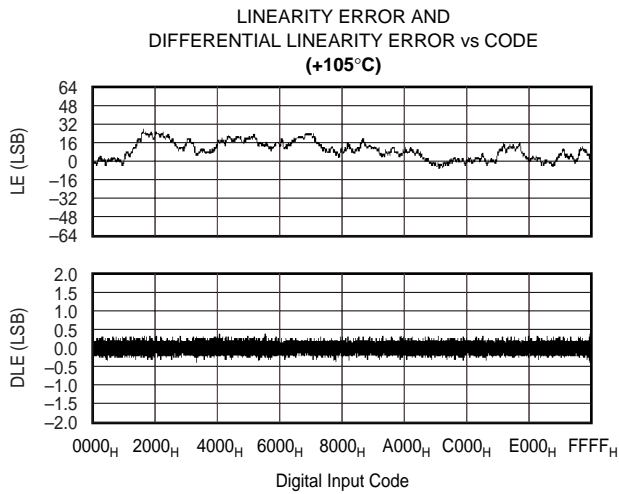
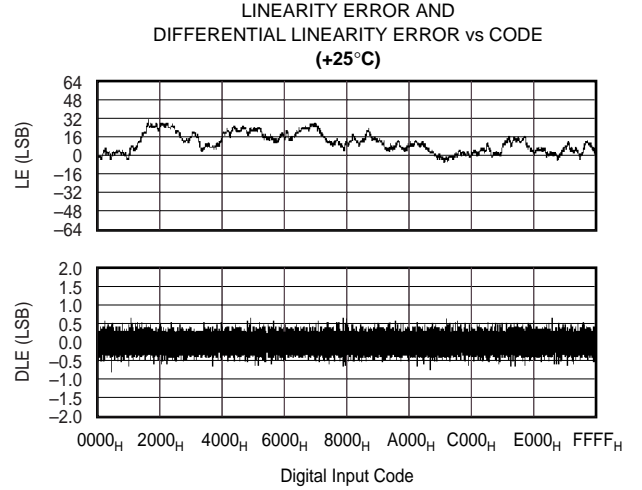
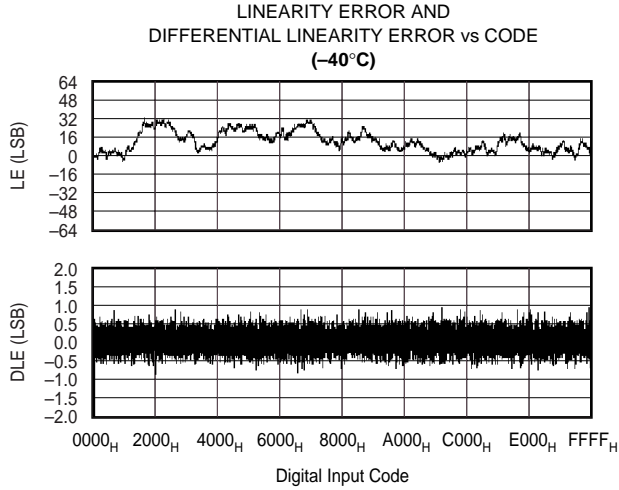

# TYPICAL CHARACTERISTICS: $V_{DD} = +5V$ (Cont.)

At  $T_A = +25^\circ C$ ,  $+V_{DD} = +5V$ , unless otherwise noted.

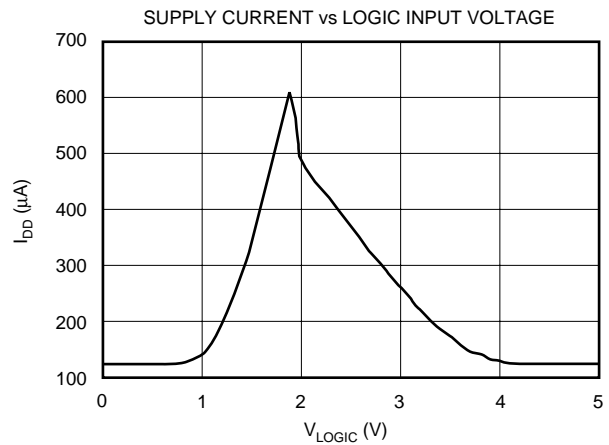
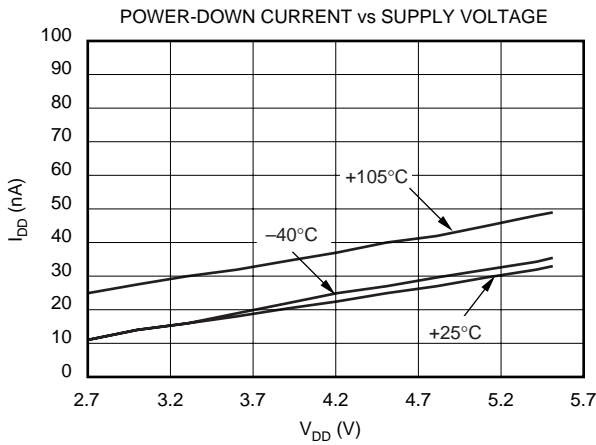
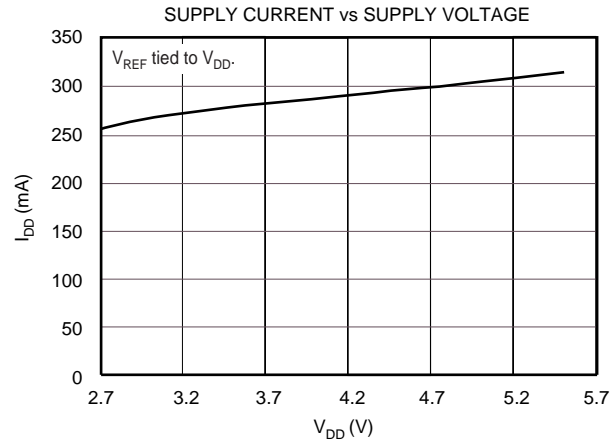
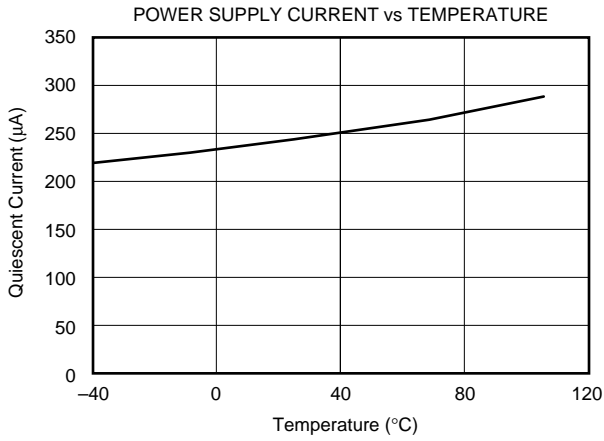
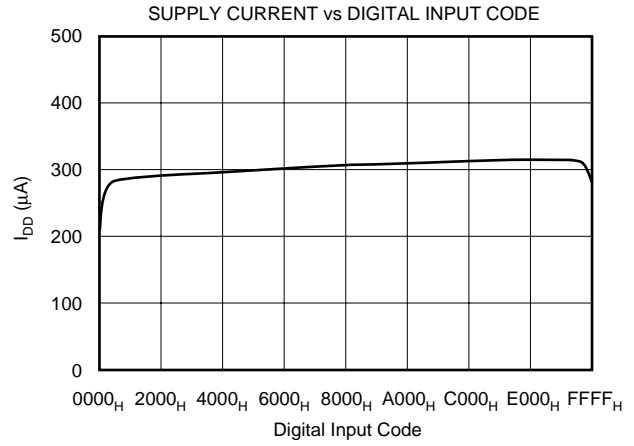
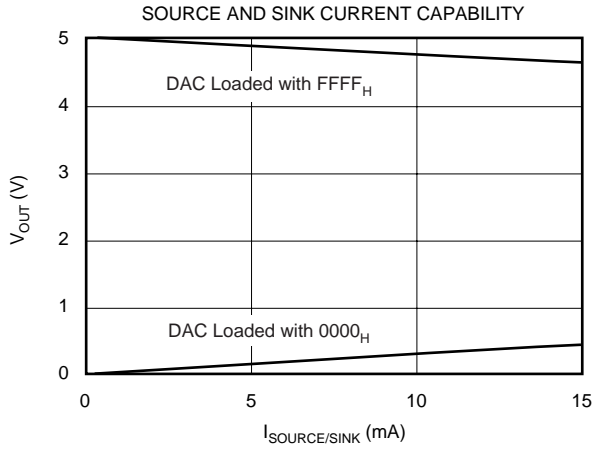

# TYPICAL CHARACTERISTICS: $V_{DD} = +5V$ (Cont.)

At  $T_A = +25^\circ C$ ,  $+V_{DD} = +5V$ , unless otherwise noted.

FULL-SCALE SETTLING TIME

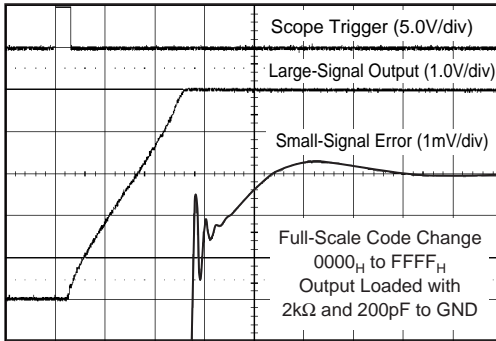

Time (2μs/div)

FULL-SCALE SETTLING TIME

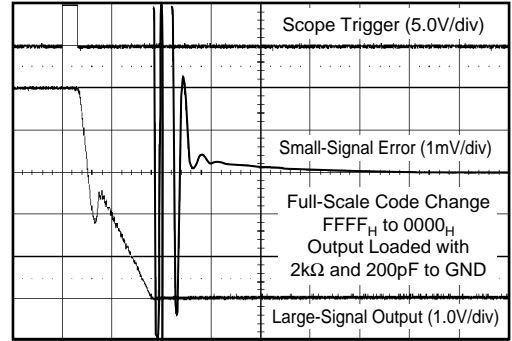

Time (2μs/div)

HALF-SCALE SETTLING TIME

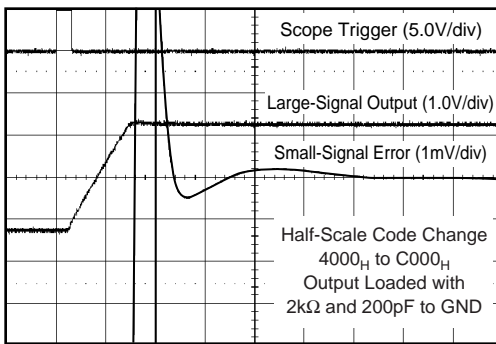

Time (2μs/div)

HALF-SCALE SETTLING TIME

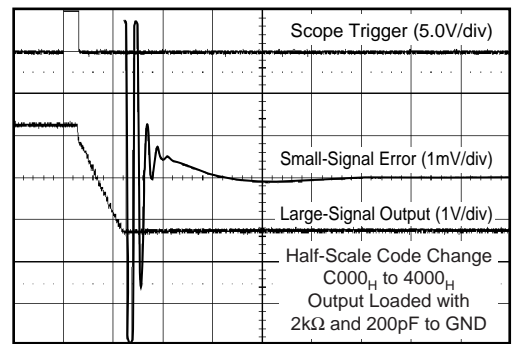

Time (2μs/div)

POWER-ON RESET TO 0V

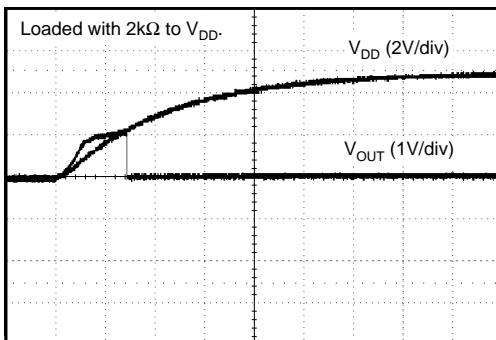

Time (50μs/div)

EXITING POWER-DOWN  
(8000<sub>H</sub> Loaded)

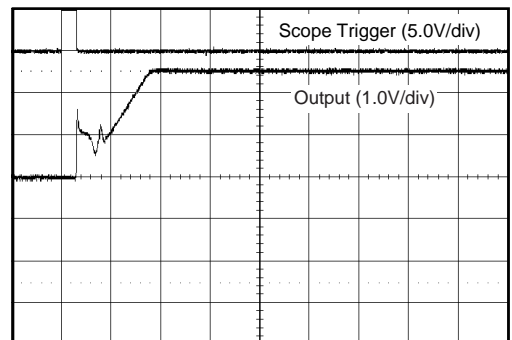

Time (2μs/div)

# TYPICAL CHARACTERISTICS: $V_{DD} = +5V$ (Cont.)

At  $T_A = +25^\circ C$ ,  $+V_{DD} = +5V$ , unless otherwise noted.

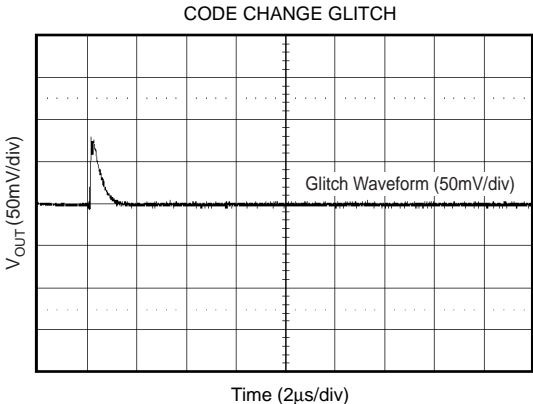



# TYPICAL CHARACTERISTICS: $V_{DD} = +2.7V$

At  $T_A = +25^\circ C$ ,  $+V_{DD} = +2.7V$ , unless otherwise noted.

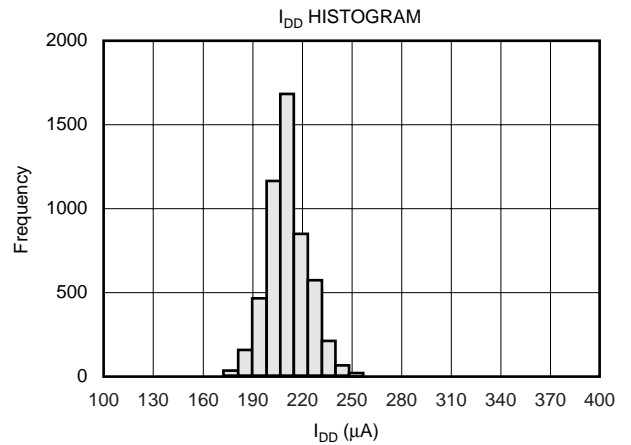
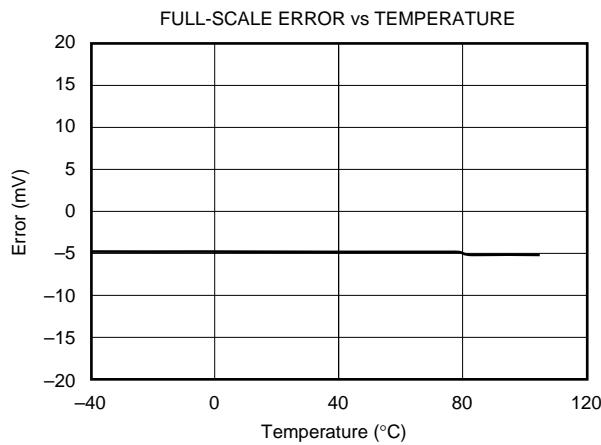
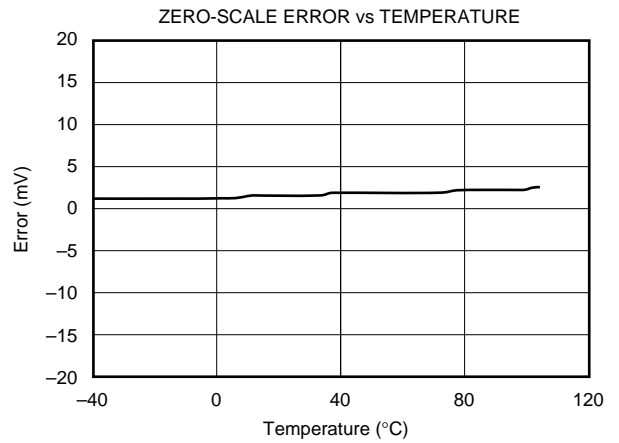
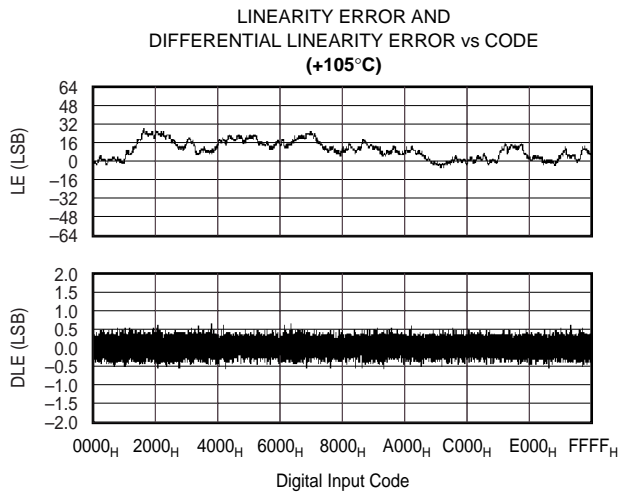
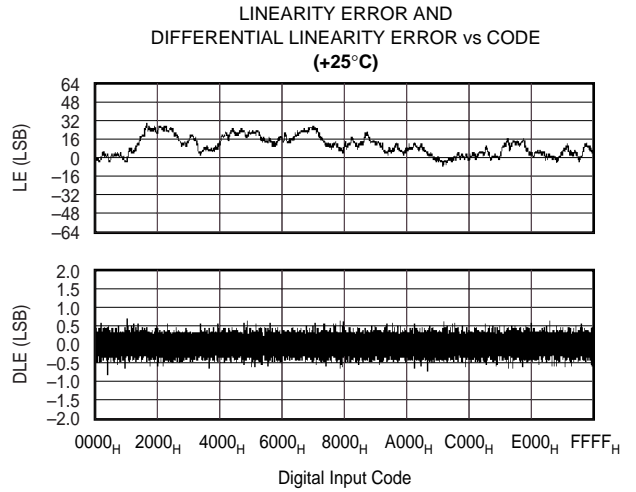
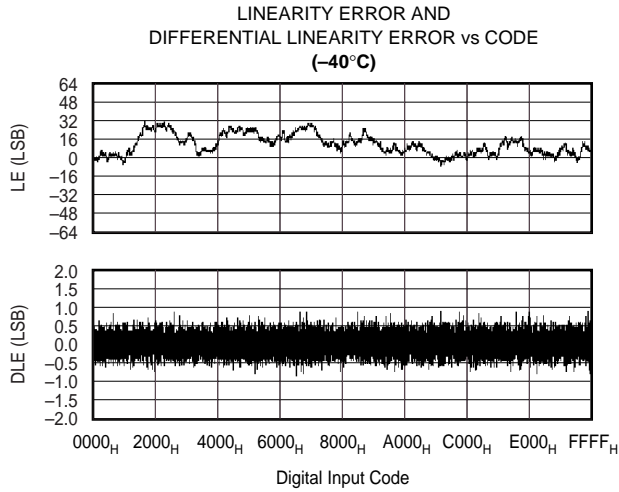

# TYPICAL CHARACTERISTICS: $V_{DD} = +2.7V$ (Cont.)

At  $T_A = +25^\circ C$ ,  $+V_{DD} = +2.7V$ , unless otherwise noted.

NOTE: All references to  $I_{DD}$  include  $I_{REF}$  current.

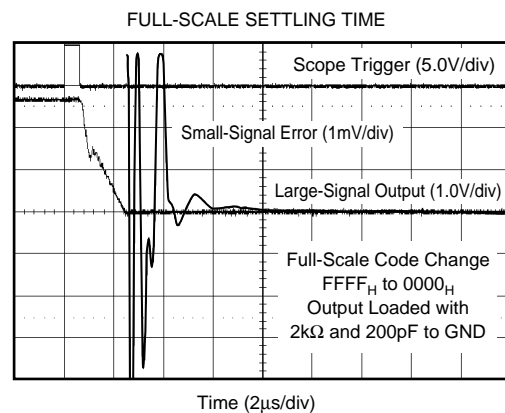
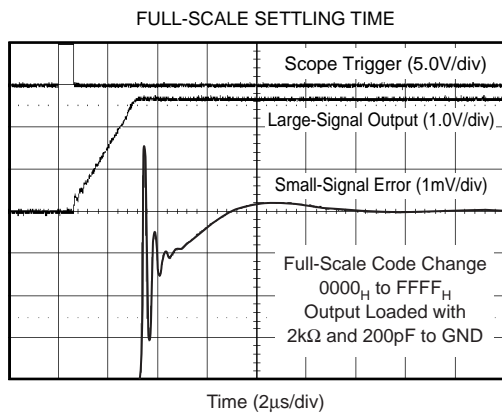
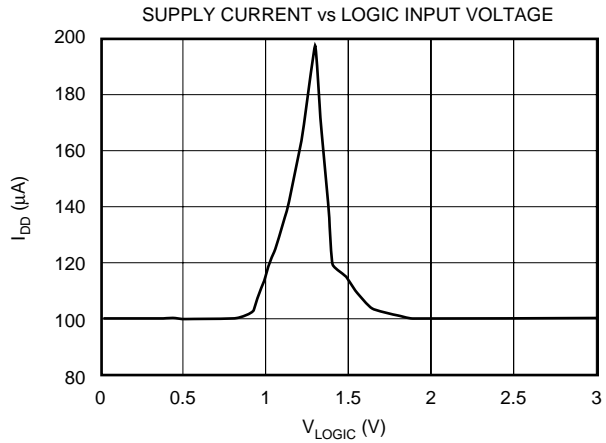
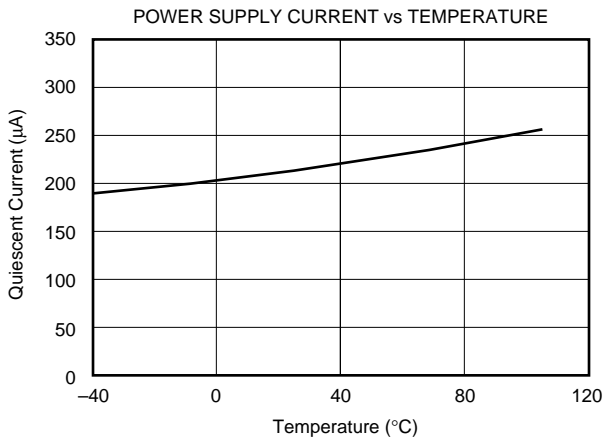
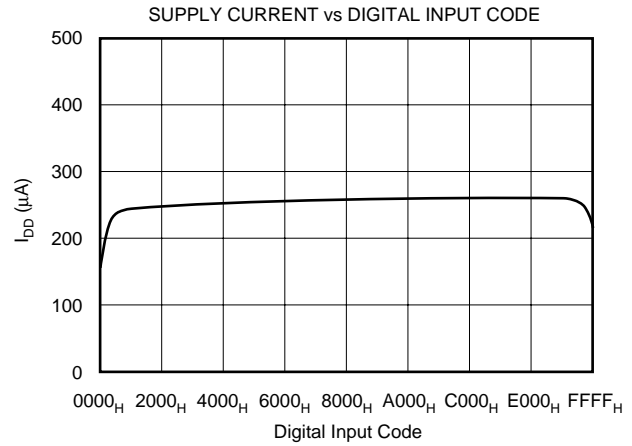
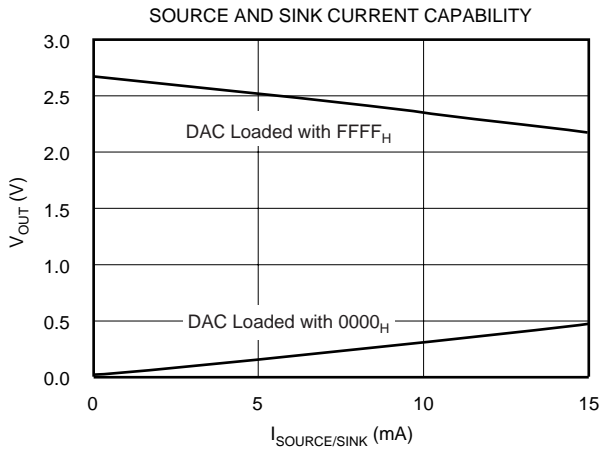

# TYPICAL CHARACTERISTICS: $V_{DD} = +2.7V$ (Cont.)

At  $T_A = +25^\circ C$ ,  $+V_{DD} = +2.7V$ , unless otherwise noted.

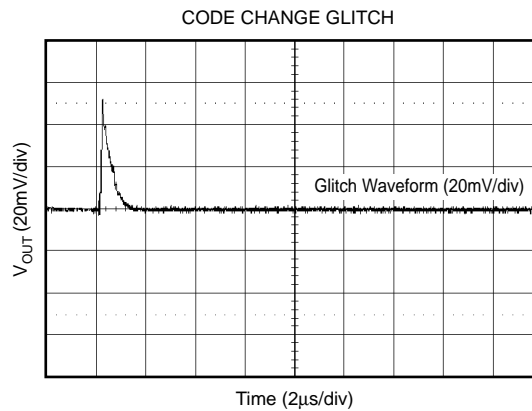
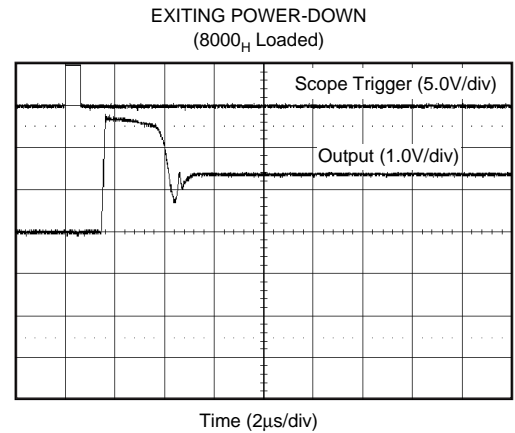
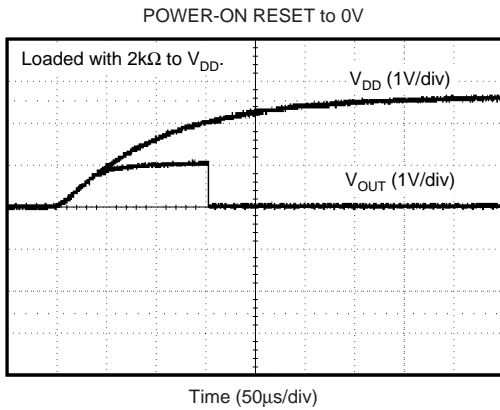
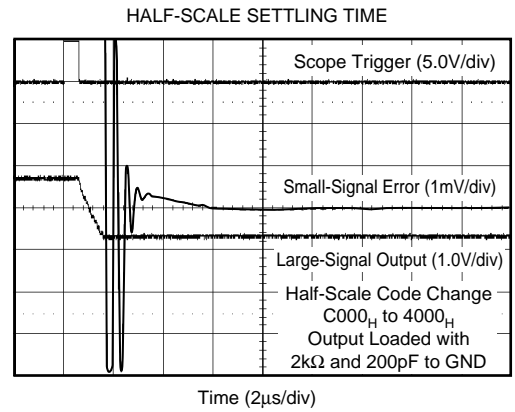
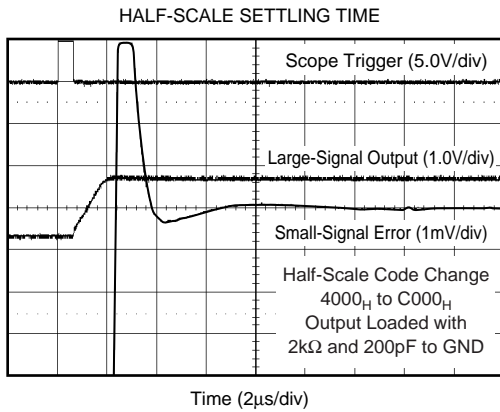

# THEORY OF OPERATION

## DAC SECTION

The architecture consists of a string DAC followed by an output buffer amplifier. Figure 1 shows a block diagram of the DAC architecture.

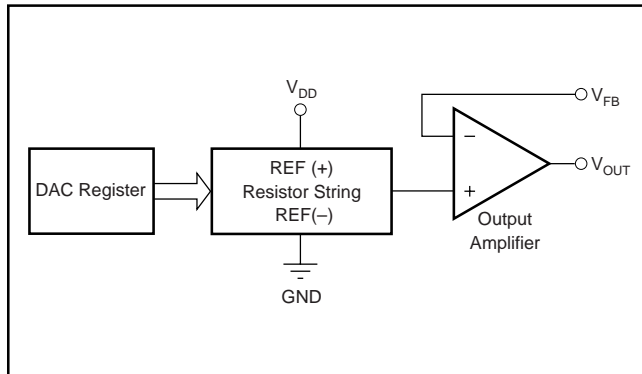

FIGURE 1. DAC8531 Architecture.

The input coding to the DAC8531 is straight binary, so the ideal output voltage is given by:

$$V_{OUT} = V_{REF} \cdot \frac{D}{65536}$$

where D = decimal equivalent of the binary code that is loaded to the DAC register; it can range from 0 to 65535.

## RESISTOR STRING

The resistor string section is shown in Figure 2. It is simply a string of resistors, each of value R. The code loaded into the DAC register determines at which node on the string the voltage is tapped off to be fed into the output amplifier by closing one of the switches connecting the string to the amplifier. It is guaranteed monotonic because it is a string of resistors.

## OUTPUT AMPLIFIER

The output buffer amplifier is capable of generating rail-to-rail voltages on its output which gives an output range of 0V to  $V_{DD}$ . It is capable of driving a load of  $2k\Omega$  in parallel with  $1000pF$  to GND. The source and sink capabilities of the output amplifier can be seen in the typical curves. The slew rate is  $1V/\mu s$  with a full-scale settling time of  $8\mu s$  with the output unloaded.

The inverting input of the output amplifier is brought out to the  $V_{FB}$  pin. This allows for better accuracy in critical applications by tying the  $V_{FB}$  point and the amplifier output together directly at the load. Other signal conditioning circuitry may also be connected between these points for specific applications.

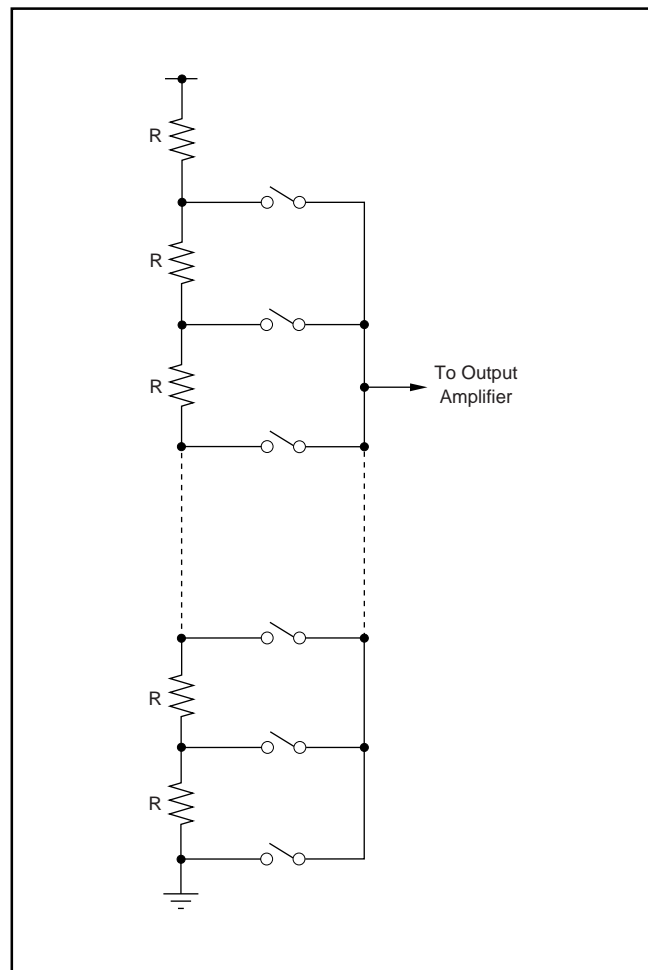

FIGURE 2. Resistor String.

## SERIAL INTERFACE

The DAC8531 has a three-wire serial interface ( $\overline{SYNC}$ , SCLK, and  $D_{IN}$ ), which is compatible with SPI, QSPI, and Microwire interface standards as well as most Digital Signal Processors (DSPs). See the Serial Write Operation timing diagram for an example of a typical write sequence.

The write sequence begins by bringing the  $\overline{SYNC}$  line LOW. Data from the  $D_{IN}$  line is clocked into the 24-bit shift register on the falling edge of SCLK. The serial clock frequency can be as high as 30MHz, making the DAC8531 compatible with high-speed (DSPs). On the 24th falling edge of the serial clock, the last data bit is clocked in and the programmed function is executed (i.e., a change in DAC register contents and/or a change in the mode of operation).

At this point, the  $\overline{SYNC}$  line may be kept LOW or brought HIGH. In either case, it must be brought HIGH for a minimum of 33ns before the next write sequence so that a falling edge of  $\overline{SYNC}$  can initiate the next write sequence. Since the  $\overline{SYNC}$  buffer draws more current when the  $\overline{SYNC}$  signal is HIGH than it does when it is LOW,  $\overline{SYNC}$  should be idled LOW between write sequences for lowest power operation of the part. As mentioned above, it must be brought HIGH again just before the next write sequence.

## INPUT SHIFT REGISTER

The input shift register is 24 bits wide, as shown in Figure 3. The first six bits are “don’t cares”. The next two bits (PD1, and PD0) are control bits that control which mode of operation the part is in (normal mode or any one of three power-down modes). There is a more complete description of the various modes in the Power-Down Modes section. The next 16 bits are the data bits. These are transferred to the DAC register on the 24th falling edge of SCLK.

## SYNC INTERRUPT

In a normal write sequence, the  $\overline{\text{SYNC}}$  line is kept LOW for at least 24 falling edges of SCLK and the DAC is updated on the 24th falling edge. However, if  $\overline{\text{SYNC}}$  is brought HIGH before the 24th falling edge, this acts as an interrupt to the write sequence. The shift register is reset and the write sequence is seen as invalid. Neither an update of the DAC register contents or a change in the operating mode occurs, as shown in Figure 4.

## POWER-ON-RESET

The DAC8531 contains a power-on-reset circuit that controls the output voltage during power-up. On power-up, the DAC register is filled with zeros and the output voltage is 0V; it remains there until a valid write sequence is made to the DAC. This is useful in applications where it is important to know the state of the output of the DAC while it is in the process of powering up.

## POWER-DOWN MODES

The DAC8531 supports four separate modes of operation. These modes are programmable by setting two bits (PD1 and PD0) in the control register. Table I shows how the state of the bits corresponds to the mode of operation of the device.

When both bits are set to 0, the part works normally with its normal power consumption of 250 $\mu$ A at 5V. However, for the three power-down modes, the supply current falls to

PD1 (DB17)	PD0 (DB16)	OPERATING MODE
0	0	Normal Operation
—	—	Power-Down Modes
0	1	Output 1k $\Omega$ to GND
1	0	Output 100k $\Omega$ to GND
1	1	High-Z

TABLE I. Modes of Operation for the DAC8531.

200nA at 5V (50nA at 3V). Not only does the supply current fall, but the output stage is also internally switched from the output of the amplifier to a resistor network of known values. This has the advantage that the output impedance of the part is known while the part is in power-down mode. There are three different options. The output is connected internally to GND through a 1k $\Omega$  resistor, a 100k $\Omega$  resistor, or it is left open-circuited (High-Z). The output stage is illustrated in Figure 5.

All linear circuitry is shut down when the power-down mode is activated. However, the contents of the DAC register are unaffected when in power-down. The time to exit power-down is typically 2.5 $\mu$ s for  $V_{DD} = 5V$ , and 5 $\mu$ s for  $V_{DD} = 3V$ . See the Typical Performance Curves for more information.

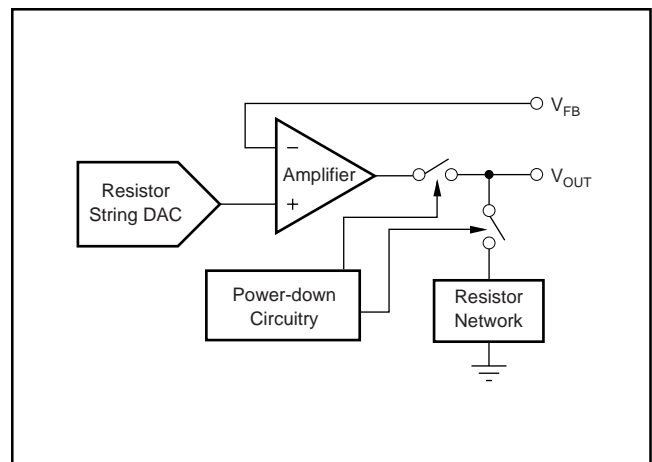

FIGURE 5. Output Stage During Power-Down.

DB15																DB0									
X	X	X	X	X	X	PD1	PD0	D15	D14	D13	D12	D11	D10	D9	D8	D7	D6	D5	D4	D3	D2	D1	D0		

FIGURE 3. Data Input Register.

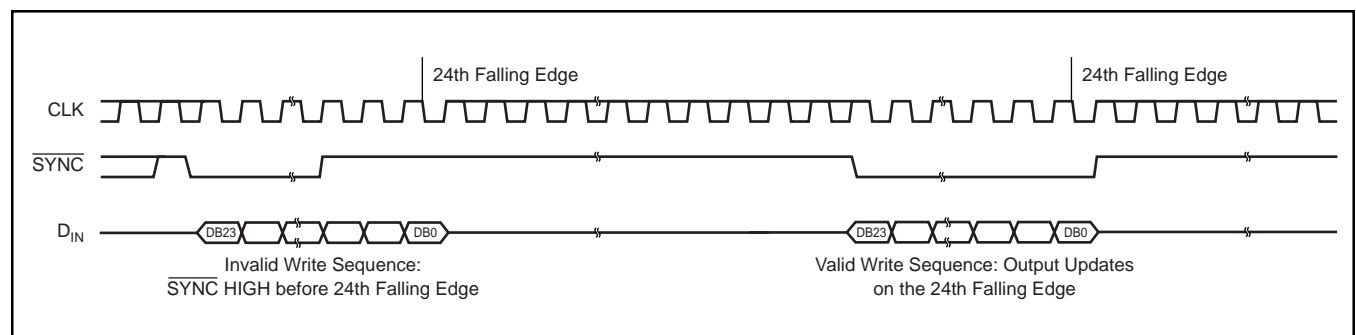

FIGURE 4.  $\overline{\text{SYNC}}$  Interrupt Facility.

# MICROPROCESSOR INTERFACING

## DAC8531 TO 8051 INTERFACE

Figure 6 shows a serial interface between the DAC8531 and a typical 8051-type microcontroller. The setup for the interface is as follows: TXD of the 8051 drives SCLK of the DAC8531, while RXD drives the serial data line of the part. The  $\overline{\text{SYNC}}$  signal is derived from a bit-programmable pin on the port. In this case, port line P3.3 is used. When data is to be transmitted to the DAC8531, P3.3 is taken LOW. The 8051 transmits data only in 8-bit bytes; thus only eight falling clock edges occur in the transmit cycle. To load data to the DAC, P3.3 is left LOW after the first eight bits are transmitted, and a second write cycle is initiated to transmit the second byte of data. P3.3 is taken HIGH following the completion of the third write cycle. The 8051 outputs the serial data in a format which has the LSB first. The DAC8531 requires its data with the MSB as the first bit received. The 8051 transmit routine must therefore take this into account, and “mirror” the data as needed.

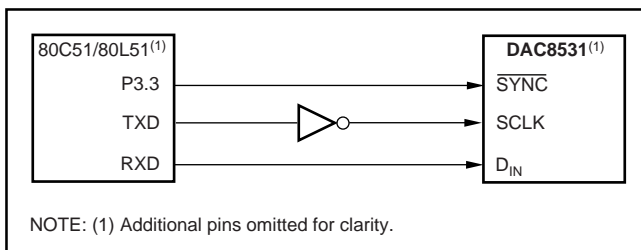

FIGURE 6. DAC8531 to 80C51/80L51 Interface.

## DAC8531 TO Microwire™ INTERFACE

Figure 7 shows an interface between the DAC8531 and any Microwire compatible device. Serial data is shifted out on the falling edge of the serial clock and is clocked into the DAC8531 on the rising edge of the SK signal.

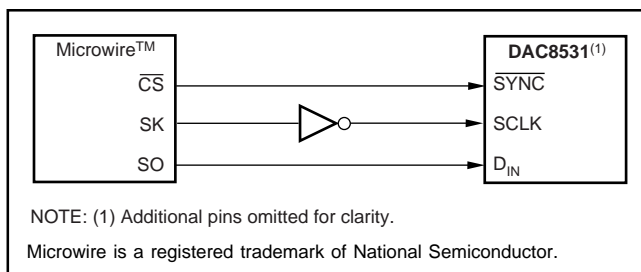

FIGURE 7. DAC8531 to Microwire Interface.

## DAC8531 TO 68HC11 INTERFACE

Figure 8 shows a serial interface between the DAC8531 and the 68HC11 microcontroller. SCK of the 68HC11 drives the SCLK of the DAC8531, while the MOSI output drives the serial data line of the DAC. The  $\overline{\text{SYNC}}$  signal is derived from a port line (PC7), similar to what was done for the 8051.

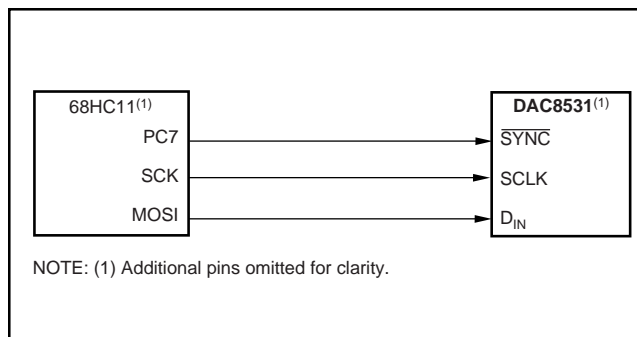

FIGURE 8. DAC8531 to 68HC11 Interface.

The 68HC11 should be configured so that its CPOL bit is a 0 and its CPHA bit is a 1. This configuration causes data appearing on the MOSI output to be valid on the falling edge of SCK. When data is being transmitted to the DAC, the  $\overline{\text{SYNC}}$  line is taken LOW (PC7). Serial data from the 68HC11 is transmitted in 8-bit bytes with only eight falling clock edges occurring in the transmit cycle. Data is transmitted MSB first. In order to load data to the DAC8531, PC7 is left LOW after the first eight bits are transferred, then a second and third serial write operation is performed to the DAC and PC7 is taken HIGH at the end of this procedure.

# APPLICATIONS

## USING REF02 AS A POWER SUPPLY FOR DAC8531

Due to the extremely low supply current required by the DAC8531, an alternative option is to use a REF02 +5V precision voltage reference to supply the required voltage to the part, as shown in Figure 9. This is especially useful if the power supply is quite noisy or if the system supply voltages are at some value other than 5V. The REF02 will output a steady supply voltage for the DAC8531. If the REF02 is used, the current it needs to supply to the DAC8531 is

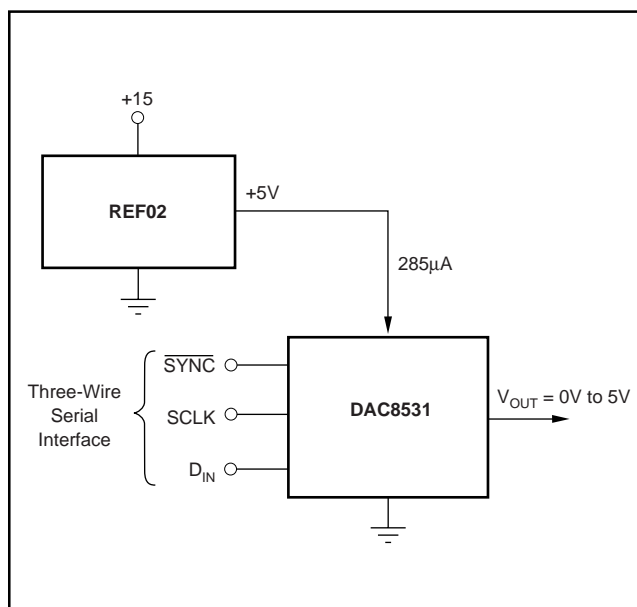

FIGURE 9. REF02 as Power Supply to DAC8531.

250 $\mu$ A. This is with no load on the output of the DAC. When the DAC output is loaded, the REF02 also needs to supply the current to the load. The total current required (with a 5k $\Omega$  load on the DAC output) is:

$$285\mu\text{A} + (5\text{V}/5\text{k}\Omega) = 1.29\text{mA}$$

The load regulation of the REF02 is typically 0.005%/mA, which results in an error of 322 $\mu$ V for the 1.29mA current drawn from it. This corresponds to a 4.2LSB error.

### BIPOLAR OPERATION USING THE DAC8531

The DAC8531 has been designed for single-supply operation but a bipolar output range is also possible using the circuit in Figure 10. The circuit shown will give an output voltage range of  $\pm V_{\text{REF}}$ . Rail-to-rail operation at the amplifier output is achievable using an OPA251 as the output amplifier.

The output voltage for any input code can be calculated as follows:

$$V_{\text{O}} = \left[ V_{\text{REF}} \cdot \left( \frac{D}{65536} \right) \cdot \left( \frac{R_1 + R_2}{R_1} \right) - V_{\text{REF}} \cdot \left( \frac{R_2}{R_1} \right) \right]$$

where D represents the input code in decimal (0–65535).

With  $V_{\text{REF}} = 5\text{V}$ ,  $R_1 = R_2 = 10\text{k}\Omega$ :

$$V_{\text{O}} = \left( \frac{10 \cdot D}{65536} \right) - 5\text{V}$$

This is an output voltage range of  $\pm 5\text{V}$  with 0000<sub>H</sub> corresponding to a  $-5\text{V}$  output and FFFF<sub>H</sub> corresponding to a  $+5\text{V}$  output. Similarly, using  $V_{\text{REF}} = 2.5\text{V}$ ,  $\pm 2.5\text{V}$  output voltage range can be achieved.

## LAYOUT

A precision analog component requires careful layout, adequate bypassing, and clean, well-regulated power supplies.

As the DAC8531 offers single-supply operation, it will often be used in close proximity with digital logic, microcontrollers, microprocessors, and digital signal processors. The more digital logic present in the design and the higher the switching speed, the more difficult it will be to keep digital noise from appearing at the output.

Due to the single ground pin of the DAC8531, all return currents, including digital and analog return currents, must flow through the GND pin. Ideally, GND would be connected directly to an analog ground plane. This plane would be separate from the ground connection for the digital components until they were connected at the power entry point of the system.

The power applied to  $V_{\text{DD}}$  should be well regulated and low noise. Switching power supplies and DC/DC converters will often have high-frequency glitches or spikes riding on the output voltage. In addition, digital components can create similar high-frequency spikes as their internal logic switches states. This noise can easily couple into the DAC output voltage through various paths between the power connections and analog output.

As with the GND connection,  $V_{\text{DD}}$  should be connected to a  $+5\text{V}$  power supply plane or trace that is separate from the connection for digital logic until they are connected at the power entry point. In addition, the 1 $\mu$ F to 10 $\mu$ F and 0.1 $\mu$ F bypass capacitors are strongly recommended. In some situations, additional bypassing may be required, such as a 100 $\mu$ F electrolytic capacitor or even a “Pi” filter made up of inductors and capacitors—all designed to essentially lowpass filter the  $+5\text{V}$  supply, removing the high-frequency noise.

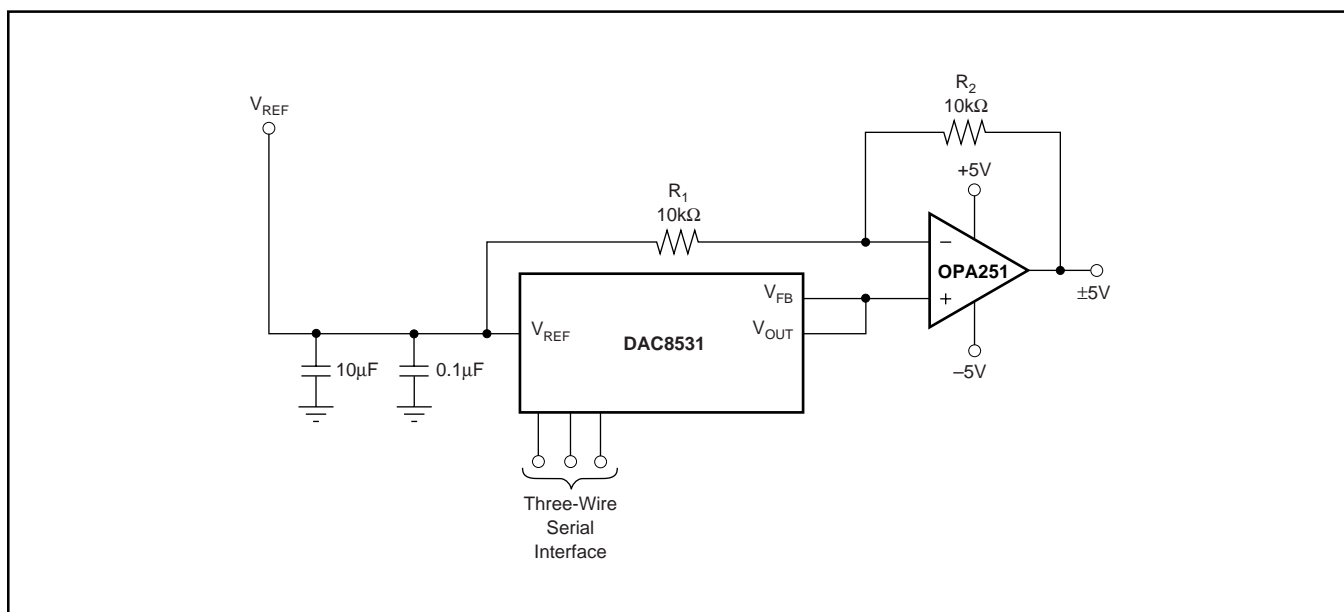

FIGURE 10. Bipolar Operation with the DAC8531.

## IMPORTANT NOTICE

Texas Instruments and its subsidiaries (TI) reserve the right to make changes to their products or to discontinue any product or service without notice, and advise customers to obtain the latest version of relevant information to verify, before placing orders, that information being relied on is current and complete. All products are sold subject to the terms and conditions of sale supplied at the time of order acknowledgment, including those pertaining to warranty, patent infringement, and limitation of liability.

TI warrants performance of its products to the specifications applicable at the time of sale in accordance with TI's standard warranty. Testing and other quality control techniques are utilized to the extent TI deems necessary to support this warranty. Specific testing of all parameters of each device is not necessarily performed, except those mandated by government requirements.

Customers are responsible for their applications using TI components.

In order to minimize risks associated with the customer's applications, adequate design and operating safeguards must be provided by the customer to minimize inherent or procedural hazards.

TI assumes no liability for applications assistance or customer product design. TI does not warrant or represent that any license, either express or implied, is granted under any patent right, copyright, mask work right, or other intellectual property right of TI covering or relating to any combination, machine, or process in which such products or services might be or are used. TI's publication of information regarding any third party's products or services does not constitute TI's approval, license, warranty or endorsement thereof.

Reproduction of information in TI data books or data sheets is permissible only if reproduction is without alteration and is accompanied by all associated warranties, conditions, limitations and notices. Representation or reproduction of this information with alteration voids all warranties provided for an associated TI product or service, is an unfair and deceptive business practice, and TI is not responsible nor liable for any such use.

Resale of TI's products or services with statements different from or beyond the parameters stated by TI for that product or service voids all express and any implied warranties for the associated TI product or service, is an unfair and deceptive business practice, and TI is not responsible nor liable for any such use.

Also see: [Standard Terms and Conditions of Sale for Semiconductor Products](http://www.ti.com/sc/docs/stdterms.htm). [www.ti.com/sc/docs/stdterms.htm](http://www.ti.com/sc/docs/stdterms.htm)

### Mailing Address:

Texas Instruments  
Post Office Box 655303  
Dallas, Texas 75265